

## Mechanism and Machines

**Mechanism:** If a number of bodies are assembled in such a way that the motion of one causes constrained and predictable motion to the others, it is known as a mechanism. A mechanism transmits and modifies a motion.

**Machine:** A machine is a mechanism or a combination of mechanisms which, apart from imparting definite motions to the parts, also transmits and modifies the available mechanical energy into some kind of desired work.

It is neither a source of energy nor a producer of work but helps in proper utilization of the same.

The motive power has to be derived from external sources.

A slider - crank mechanism converts the reciprocating motion of a slider into rotary motion of the crank or vice versa.

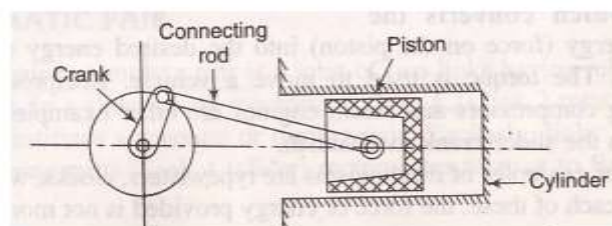

Figure-1

(Available) force on the piston → slider crank + valve mechanism → Torque of the crank shaft (desired).

Examples of slider crank mechanism → Automobile Engine, reciprocating pumps, reciprocating compressor, and steam engines.

Examples of mechanisms: type writer, clocks, watches, spring toys.

**Rigid body:** A body is said to be rigid if under the action of forces, it does not suffer any distortion.

Resistant bodies: Those which are rigid for the purposes they have to serve.

Semi rigid body: Which are normally flexible, but under certain loading conditions act as rigid body for the limited purpose.

Example: 1. Belt is rigid when subjected to tensile forces. So belt-drive acts as a resistant body. 2. Fluid is resistant body at compressive load.

Link: A resistant body or a group of resistant bodies with rigid connections preventing their relative movement is known as a link.

A link may also be defined as a member or a combination of members of a mechanism, connecting other members and having motion relative to them.

A link is also known as kinematic link or element.

Links can be classified into binary, ternary, quarternary, etc, depending upon their ends on which revolute or turning pairs can be placed.



Figure-2

Kinematic pair:

A kinematic pair or simply a pair is a joint of two links having relative motion between them.

Types of kinematic pairs: Kinematic pairs can be classified according to

- (i) Nature of contact
- (ii) Nature of mechanical constraint
- (iii) Nature of relative motion

Kinematic pairs according to nature of contact

- (a) Lower pair: A pair of links having surface or area contact between the members is known as a lower pair. Example: – Nut and screw, shaft rotating in bearing, all pairs of slider crank mechanism, universal joint etc.
- (b) Higher pair: When a pair has a point or line contact between the links, it is known as a higher pair. Example: – Wheel rolling on a surface, cam and follower pair, tooth gears, ball and roller bearings.

### Kinematic pairs according to nature of mechanical constraint

- (a) Closed pair : When the elements of a pair are held together mechanically, it is known as a closed pair. The contact between the two can be broken only by destruction of at least one of the member.
- (b) Unclosed pair : When two links of a pair are in contact either due to force of gravity or some spring action, they constitute an unclosed pair.

### Kinematic pairs according to nature of relative motion:

- (a) Sliding pair: If two links have a sliding motion relative to each other, they form a sliding pair.
- (b) Turning pair: When one link has a turning or revolving motion relative to the other, they constitute a turning or revolving pair.
- (c) Rolling Pair: When the links of a pair have a rolling motion relative to each other, they form a rolling pair.
- (d) Screw pair: If two mating links have a turning as well as sliding motion between them, they form a screw pair. Ex – lead screw and nut.
- (e) Spherical pair: When one link in the form of a sphere turns inside a fixed link, it is a spherical pair. Ex – ball and socket joint.

### Degrees of freedom:

An unconstrained rigid body moving in space can describe the following independent motions.

1. Translational motion along any three mutually perpendicular axes  $x$ ,  $y$ ,  $z$  and
2. Rotational motions about these axes. Thus, a rigid body possesses six degrees of freedom.

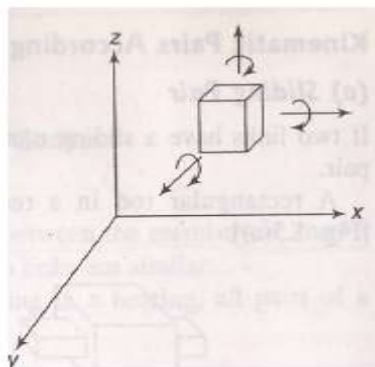

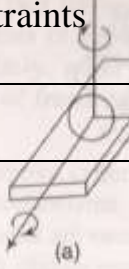
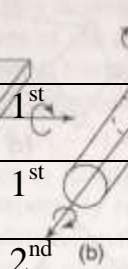
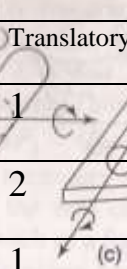

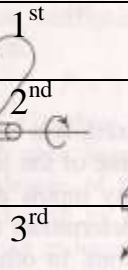
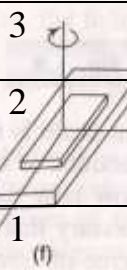

Figure - 3

Degrees of freedom of a pair are defined as the number of independent relative motions both translational and rotational. A pair in space can have,

$$\text{DOF} = 6 - \text{number of restraints.}$$

Classification of kinematic pairs:

Depending upon the number of restraints imposed on the relative motion of the two links connected together, a pair can be classified as

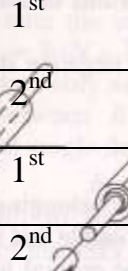
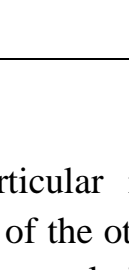
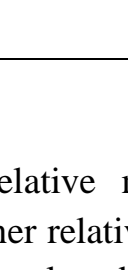
Class	Number of restraints	Form	Restraint on		Kinematic pair	Figure - 4
			Translatory	Rotary		
I	1		1	0	Sphere – plane	a
II	2		2	0	Sphere – cylinder	b
			1	1	Cylinder – plane	c
III	3		3	0	Spheric	d
			2	1	Sphere – slotted cylinder	e
			1	2	Prism – plane	f
IV	4		3	1	Slotted – spheric	g
			2	2	Cylinder – cylinder	h
V	5		3	2	Cylinder – collar	i
			2	3	Prismatic bar in prismatic hole	j

A particular relative motion between two links of a pair must be independent of the other relative motions that the pair can have. A screw and nut pair permits translational and rotational motions. However as the two motion cannot be accomplished independently, a screw and nut pair is a kinematic pair of the fifth class.

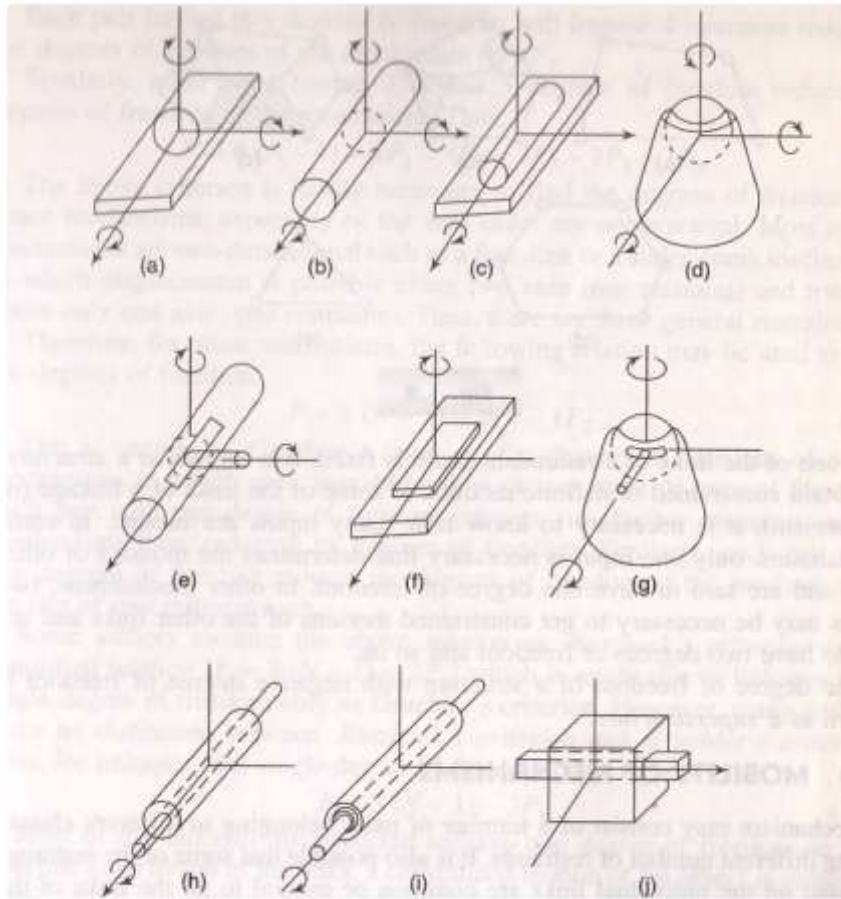

Figure – 4

Kinematic chain:

A kinematic chain is an assembly of links in which the relative motions of the links is possible and the motion of each relative to the other is definite.

Non – kinematic chain:

In case the motion of a link results in definite motions of other links, it is a non–kinematic chain.

A redundant chain: A redundant chain does not allow any motion of a link relative to the other.

Linkage:

A linkage is obtained if one of the links of a kinematic chain is fixed to the ground. If motion of any of the movable links results in definite motions of the others the linkage is known as a mechanism.

If one of the links of a redundant chain is fixed, it is known as a structure.

Mobility of mechanisms:

According to the number of general or common restraints a mechanism may be classified into different order.

A sixth order mechanism cannot exist since all the links become stationary and no movement is possible.

Degrees of freedom of a mechanism in space can be determined as follows.

Let  $N$  = total number of link in a mechanism  
 $F$  = degree of freedom.  
 $P_1$  = number of pairs having one degree of freedom.  
 $P_2$  = number of pairs having two degree of freedom

In mechanism one link is fixed

Number of degrees of freedom of  $(N-1)$  movable links =  $6(N-1)$  pair having one degree of freedom imposes 5 restraints on the mechanism reducing its degrees of freedom by  $5P_1$ .

Thus,  $F = 6(N-1) - 5P_1 - 4P_2 - 3P_3 - 2P_4 - 1P_5$

For plane mechanisms, the following relation may be used to find the degree of freedom.

$$\boxed{F = 3(N-1) - 2P_1 - 1P_2} \rightarrow \text{Gruebler's criterion.}$$

If the linkage has single degree of freedom then  $P_2 = 0$ , Hence

$$\boxed{F = 3(N-1) - 2P_1}$$

Most of the linkage are expected to have one degree of freedom.

$$\Rightarrow 1 = 3(N-1) - 2P_1$$

$$\Rightarrow 2P_1 = 3N - 4$$

As  $P_1$  and  $N$  are to be whole numbers, the relation can be satisfied only if as follows

$$N = 4, \quad P_1 = 4$$

$$N = 6, \quad P_1 = 7$$

$$N = 8, \quad P_1 = 10$$

Thus with the increase in the number of links, the number of excess turning pairs goes on increasing. To get required number of turning pairs from the required number of binary links not possible. Therefore the excess or the additional pairs or joints can be obtained only from the links having more than two joining points

## Equivalent Mechanisms:

It is possible to replace turning pairs of plane mechanisms by other type of pairs having one or two degrees of freedom, such as sliding pairs or cam pairs.

1. Sliding pair can be replaced as a turning pair with infinite length of radius.

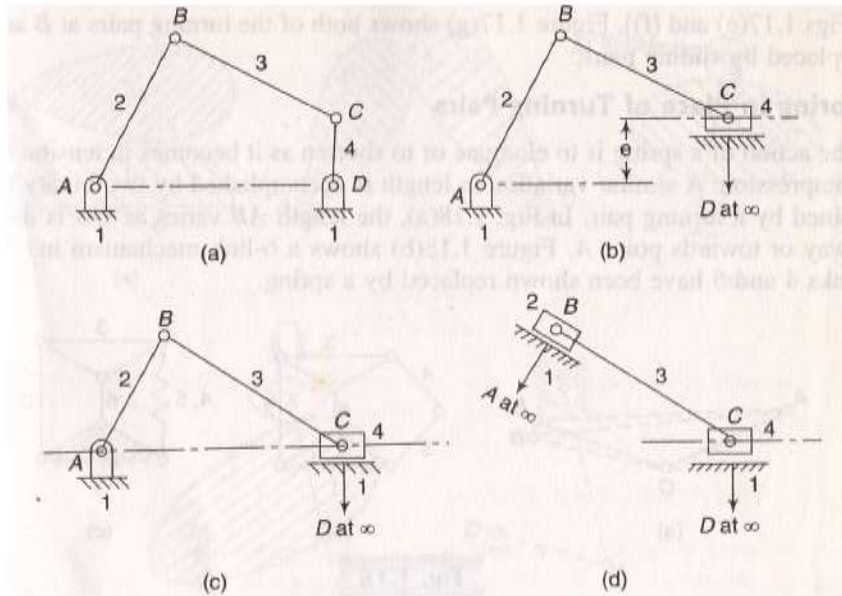

Figure - 5

2. Two sliding pair can be replaced as two turning pair if their sliding axes intersect.
3. The action of a spring is to elongate or to shorten as it becomes in tension or in compression. A similar variation in length is accomplished by two binary links joined by a turning pair.

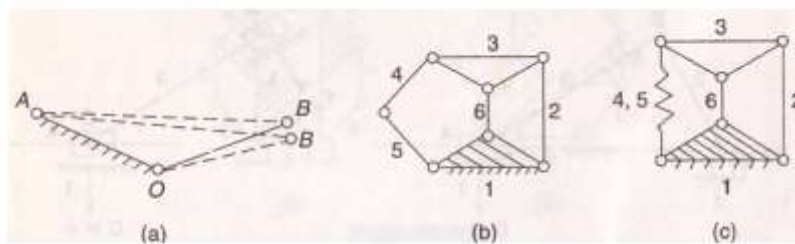

Figure - 6

4. A cam pair has two degrees of freedom



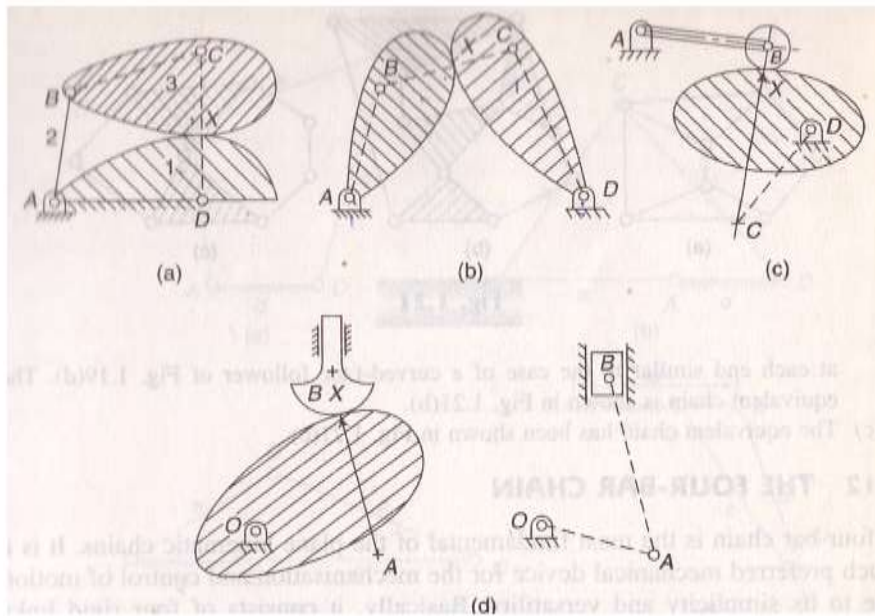

Figure - 7

$$F = 3(N - 1) - 2P_1 - 1P_2$$

A cam pair can be replaced by one binary link with two turning pairs at each end.

The Four- bar chain:

A link that makes complete revolution is called the crank. The link opposite to the fixed link is called coupler and the fourth link is called lever or rocker if it oscillates or another crank if rotates. Condition for four-bar linkage is

$$d < a + b + c$$

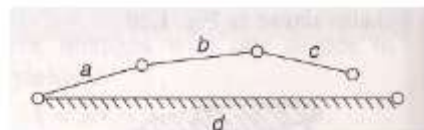

Figure - 8

Let  $a > d$ , then three extreme situations can be possible



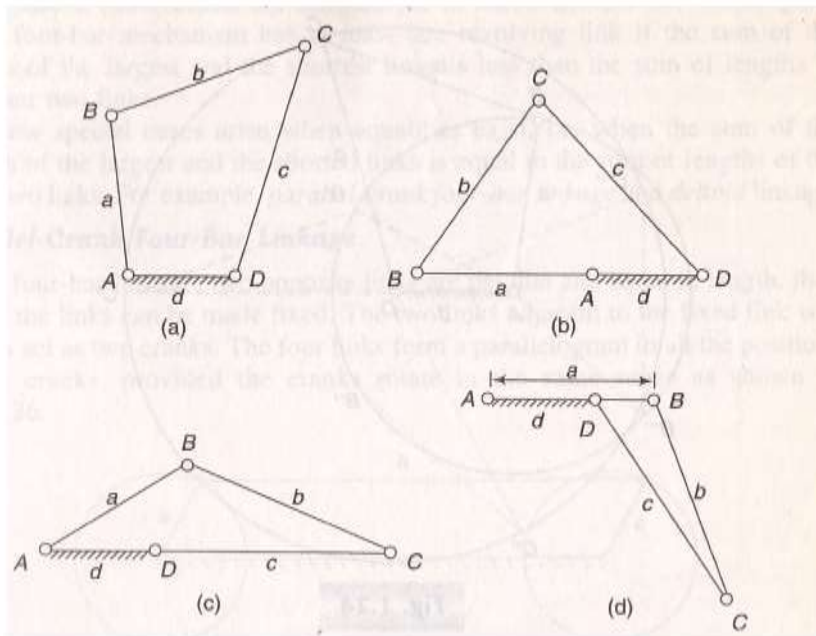

Figure - 9

(i)  $d + a < b + c$

(ii)  $d + c < a + b$

(iii)  $d + b < c + a$

Adding (i) and (ii)  $\Rightarrow 2d < 2b \quad \Rightarrow d < b$

Adding (ii) and (iii)  $\Rightarrow 2d < 2a \quad \Rightarrow d < a$

Adding (iii) and (i)  $\Rightarrow 2d < 2c \quad \Rightarrow d < c$

Thus the necessary conditions for the link 'a' to be a crank are that the shortest link is fixed and the sum of the shortest and the longest link is less than the sum of other two links.

If 'd' is fixed then a and c can rotate around d and also b; this is called drag – crank mechanism or rotary – rotary converter, or crank – crank or double crank mechanism.

B will rotate about a, if  $\angle ABC$  is greater than  $180^\circ$  in any case, and b will rotate about c if  $\angle DBC$  is more than  $180^\circ$  in any case.

Different mechanisms obtained by fixing different links of this kind of chain will be as follows (known as inversion).

1. If any of the adjacent links of link d i.e. a or c is fixed, d can have full revolution and link opposite to it oscillates. It is known as crank – rocker or crank- lever mechanism or rotary – oscillatory converter.
2. If the link opposite to the shortest link, i.e. link b is fixed and the shortest link d is made coupler, the other two links a and c would oscillate. The mechanism is called rocker – rocker or double – rocker or double –lever mechanism or oscillating – oscillating converter.

Shortest + longest < sum of other two → class-I four bar linkage.

Shortest + longest > sum of other two → class-II fourbar linkage.

All inversion s of class-II four bar linkage will give double rocker mechanism.

The above observations are summarized in the Grashof's law, which states that a four bar mechanism has at least one revolving link if the sum of the lengths of the largest and the shortest links is less than the sum of the lengths of the other two links.

Special cases when shortest+ longest = sum of other two.

Parallel – crank four bar: If  $b \parallel d$  (two opposite links are parallel) then all the inversions will be crank – crank mechanism. Ex : Parallel mechanism and anti parallel mechanism.

Deltoid linkage: If shortest link fixed → a double – crank mechanism is obtained, in which one revolution of the longer link causes two revolutions of the other shorter links.

If any of the longer links is fixed two crank – rocker mechanisms are obtained.

Mechanical advantage:

The mechanical advantage of a mechanism is the ratio of the output force or torque to the input force or torque at an instant. Let friction and inertia forces are neglected.

$$M.A. = \frac{\text{out put force/torque}}{\text{input force/torque}}$$

Power input = power output (If loss is zero)

$$T_2\omega_2 = T_4\omega_4$$

$$\Rightarrow M.A. = \frac{T_4}{T_2} = \frac{\omega_2}{\omega_4} = \text{ratiprocal of velocity ratio}$$

In case crank rocker mechanism  $\omega_4$  of the output link is zero at extreme positions, i.e. when input link is in line with coupler link or  $\gamma = 0^\circ$  or  $180^\circ$ , the mechanical advantage is infinity. Only a small input torque can overcome a large output torque load. The extreme positions of the linkage are known as toggle positions.

Transmission angle:

The angle  $\mu$  between the out put link and the coupler is known as transmission angle. The torque transmitted to the output link is maximum when the transmission angle  $\mu$  is  $90^\circ$ . If  $\mu = 0^\circ, 180^\circ$ , the mechanism would lock or jam.

If  $\mu$  deviates significantly from  $90^\circ$  the torque on output link decreases. Hence  $\mu$  is usually kept more than  $45^\circ$ .

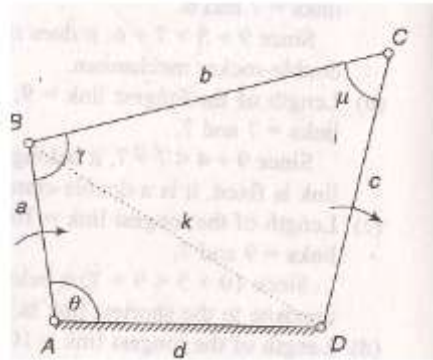

Figure - 10

Applying cosine law to triangles ABD and BCD,

$$a^2 + d^2 - 2ad \cos\theta = k^2$$

$$b^2 + c^2 - 2bc \cos\mu = k^2$$

$$\Rightarrow a^2 + d^2 - 2ad \cos \theta = b^2 + c^2 - 2bc \cos \mu$$

$$\Rightarrow a^2 + d^2 - b^2 - c^2 - 2ad \cos \theta + 2bc \cos \mu = 0$$

The maximum or minimum values of transmission angle can be found out by putting  $d\mu / d\theta$  equal to zero. Differentiating with  $\theta$

$$\Rightarrow ad \sin \theta - bc \sin \mu \times \frac{d\mu}{d\theta} = 0$$

$$\Rightarrow \frac{d\mu}{d\theta} = \frac{ad \sin \theta}{bc \sin \mu}$$

$\frac{d\mu}{d\theta}$  is zero when  $\theta = 0^\circ$  or  $180^\circ$ .

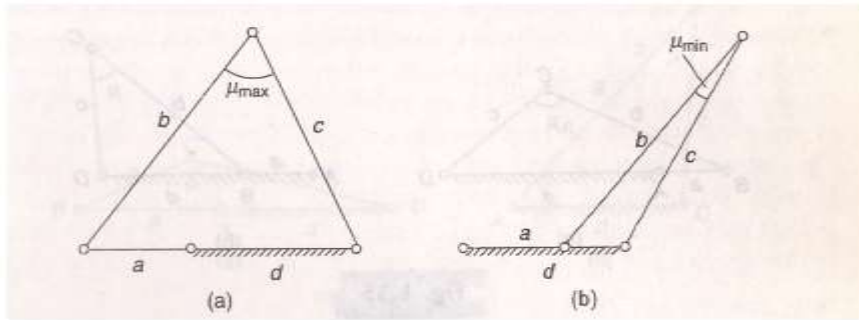

Figure - 11

The slider crank chain:

When one of the turning pairs of four bar chain is replaced by a sliding pair, it is called as single – slider crank chain or slider crank chain.

When two of turning pairs of four bar chain is replaced by two sliding pair, it is called as double slider – crank chain.

If the sliding path line passes parallel with the fixed pivot point with some offset then it is called offset slider crank chain.

Inversions of single slider crank chain:

Different mechanisms obtained by fixing different links of a kinematic chain are known as its inversions.

1<sup>st</sup> Inversion: The inversion is obtained when link 1 is fixed and links 2 and 4 are made the crank and the slider respectively.

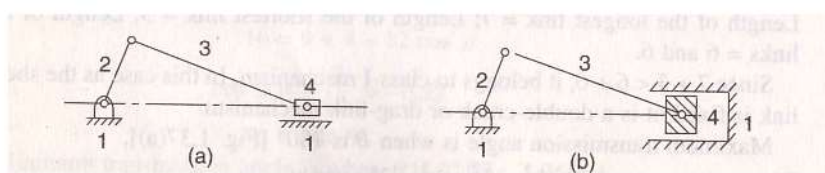

Figure - 12

- Applications:
1. Reciprocating engine.
  2. Reciprocating compressor.

2<sup>nd</sup> Inversion: Fixing of link 2 of a slider – crank chain results in the second inversion. When its link 2 is fixed instead of link 1, link 3 along with the slider at its end B becomes a crank. This makes link 1 to rotate about o along with the slider which also reciprocates on it.

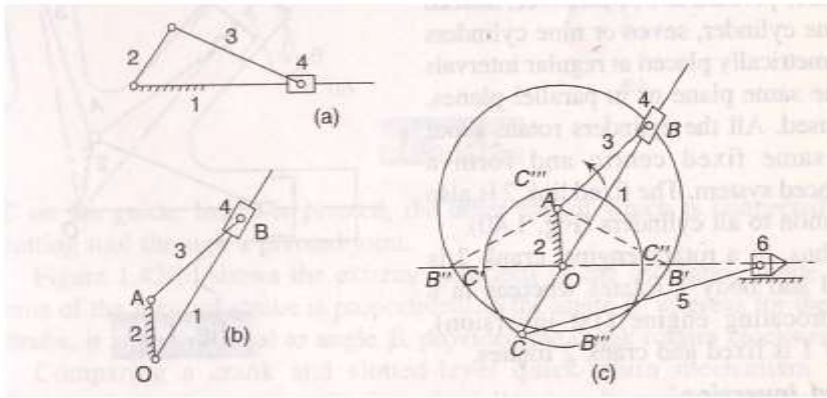

Figure - 13

- Applications:
1. White worth quick- return mechanism
  2. Rotary engine.

3<sup>rd</sup> Inversion: By fixing link 3 of the slider crank mechanism, third inversion is obtained. Here link 2 again acts as a crank and link 4 oscillates.

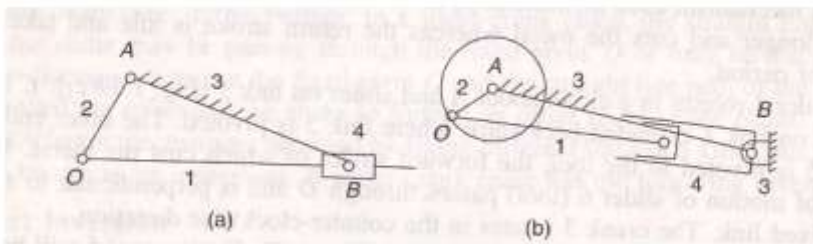

Figure - 14

- Applications:
1. Oscillating cylinder engine

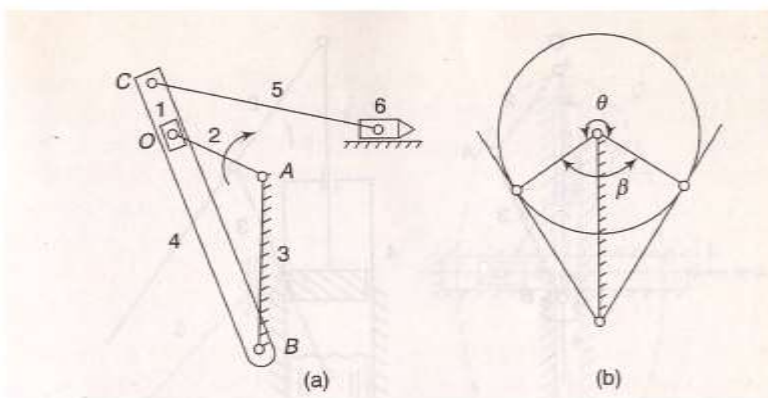

Figure - 15

2. Crank and slotted – lever mechanism.

4<sup>th</sup> Inversion: If link 4 of the slider – crank mechanism is fixed the fourth inversion is obtained. Link 3 can oscillate about the fixed pivot B on link 4. This

makes end A of link 2 to oscillate about B and end O to reciprocate along the axis of the fixed link 4.

Applications: Hand pump.

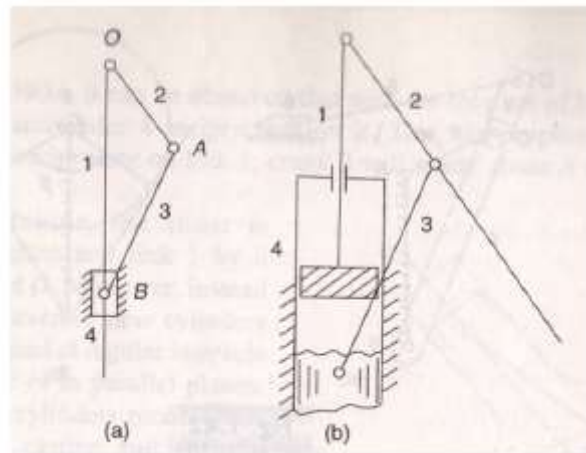

Figure - 16

Inversion of double slider – crank chain:

First inversion: The inversion is obtained when link 1 is fixed and the two adjacent pairs 23 and 34 are turning pairs and the other two pairs 12 and 41 sliding pairs.

Application: Elliptical trammel.

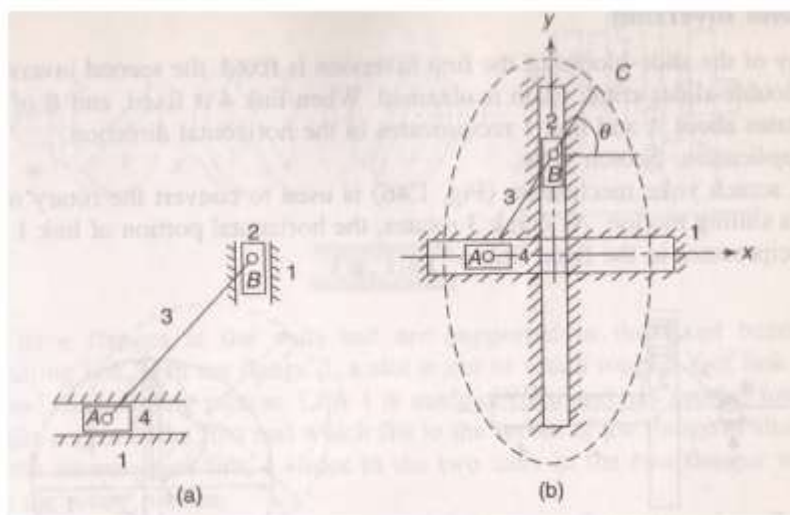

Figure - 17

Second Inversion: If any of the slide – blocks of the first inversion is fixed, the second inversion of the double – slider – crank chain is obtained. When link 4 is

fixed, end B of crank 3 rotates about A and link 1 reciprocates in the horizontal direction.

Application : Scotch yoke.

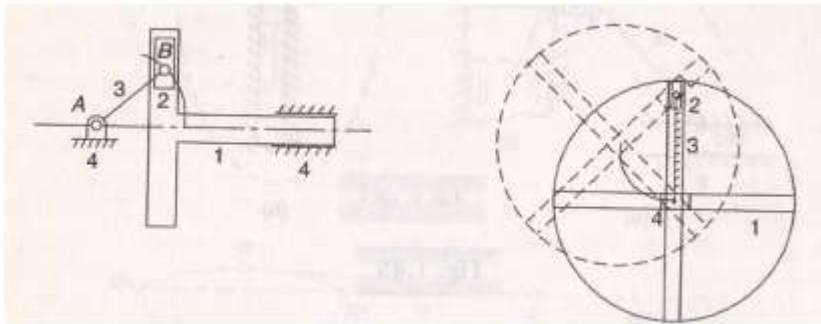

Figure - 18

Third Inversion: This inversion is obtained when link 3 of the first inversion is fixed and link 1 is free to move.

Application: Oldham's coupling.

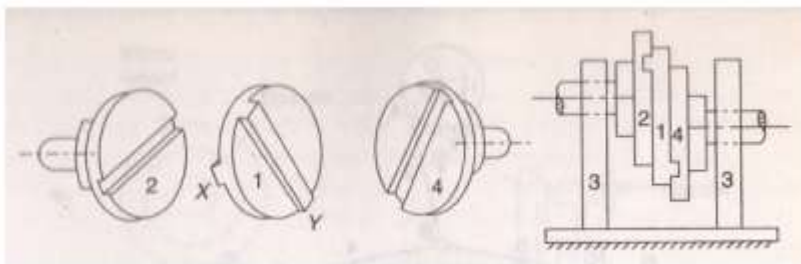

Figure - 19

Oldham coupling is used to connect two parallel shafts when the distance between their axes is small.